

## SAILING INSTRUCTIONS SNIPE CLASS INTERNATIONAL RACING ASSOCIATION

Snipe Class Italian Championship  
23-26 May 2024

21<sup>st</sup> Snipe Class German Open  
24-26 May 2024

Associazione Velica Trentina Asd  
Caldonazzo Lake, Italy

[NP] denotes a rule that shall not be grounds for protests by a boat. This changes RRS 60.1(a)

### 1 RULES

---

The regatta will be governed by:

- 1.1 The rules as defined in the Racing Rules of Sailing. (RRS)
- 1.2 The SCIRA Rules of Conduct for Conducting National and International Championship Regattas (RoC) available at  
[https://www.snipe.org/images/2021/SCIRA\\_2021\\_Rules\\_of\\_Conduct\\_final.pdf](https://www.snipe.org/images/2021/SCIRA_2021_Rules_of_Conduct_final.pdf).
- 1.3 If there is a conflict between languages the Italian will take precedence.

### 2 CHANGES TO SAILING INSTRUCTIONS

---

- 2.1 Any change to the sailing instructions will be posted before 10.00 on the day it will take effect, except that any change to the schedule of races will be posted by 19.00 on the day before it will take effect.
- 2.2 Any change or amendment to the Sailing Instructions shall be approved with the SCIRA Representative.

### 3 COMMUNICATIONS WITH COMPETITORS

---

- 3.1 Notices to competitors for Italian championship will be posted on the official notice board(s) located at the following url  
<https://federvela.coninet.it/#/manifestazioni/60534/note>  
For competitors of 21<sup>st</sup> German Open will be at this url  
<https://federvela.coninet.it/#/manifestazioni/60496/note>

### 4. CODE OF CONDUCT

---

- 4.1 [DP] Competitors and support persons shall comply with reasonable requests from race officials.
- 4.2 [DP] Competitors and support persons, if applicable, shall place advertising provided by the organizing authority with care, seamanship, in accordance with any instructions for its use and without interfering with its functionality.

## 5 SIGNALS MADE ASHORE

---

5.1 Signals made ashore will be displayed at the official flag mast positioned on the club house roof.

5.2 When the “AP” race signal is displayed ashore, ‘1 minute’ is replaced with ‘not less than 40 minutes in the race signal “AP”’. This changes Race Signals.

5.3 [DP] Flag D with one sound means ‘Boats shall not leave the shore until this signal is made. The warning signal will not be made before the scheduled time or less than 40 minutes after flag D is displayed.

## 6 SCHEDULE OF RACES

---

6.1 Dates of racing:

| Date | time of warning signal |                       |
|------|------------------------|-----------------------|
| 23/5 | 11.30                  | competitors’ briefing |
| 23/5 | 13.30                  | races                 |
| 24/5 | 10.30                  | competitors’ briefing |
| 24/5 | 12.30                  | races                 |
| 25/5 | tbd                    | races                 |
| 26/5 | tbd                    | races                 |

6.2 The regatta shall consist of 8 races for Italian Championship and 6 races for 21<sup>st</sup> German Open.

6.3 There will be a competitors meeting before the first race , at 11.30 a.m. on May 23<sup>rd</sup> and at 10.30 a.m. on May 24<sup>th</sup> and announced by two sound signals.

## 7 CLASS FLAGS

---

7.1 The official Class Flag shall be the Snipe Class flag, a Snipe silhouette on a white background.

## 8 RACING AREAS

---

8.1 The Racing Area location is the water in front of the club house.

## 9 THE COURSES

---

9.1 The diagrams below show the courses, including the approximate angles between legs, the order in which marks are to be passed. All course marks (except gates) shall be left to port.

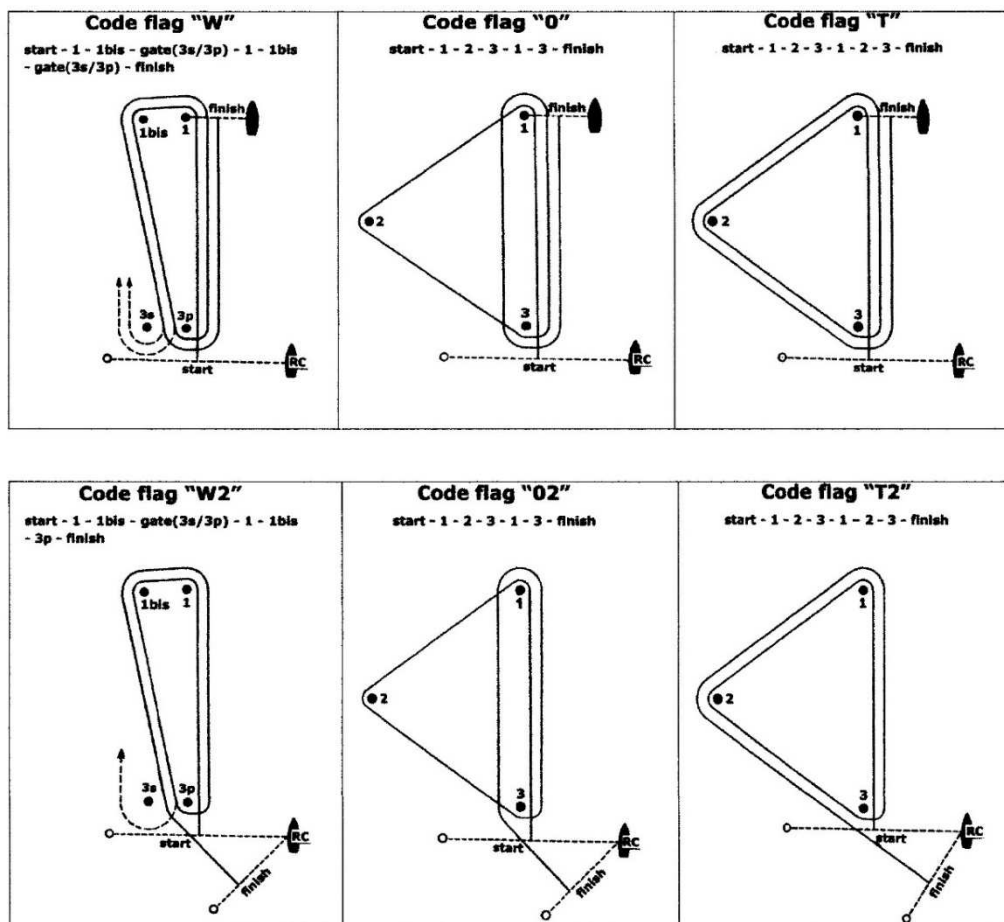

9.2 The course signal (code flag "W", "T", "O", "W2", "T2" or "O2") shall be hoisted with one sound at last one minute before the warning signal. It will remain displayed for not less than five minutes after the start.

9.3 No later than the warning signal, the Race Committee signal boat may display the approximate compass bearing of the first leg.

9.4 If during a race the wind and/or wave action changes to the point where the selected course would be inadvisable (See Course Selection Diagram), the Race Committee shall change the course at any mark. A change of the type of course during the race shall be signalled displaying the new appropriate flag and accompanied by repetitive sounds before the leading boat has passed or rounded the mark.

9.5 A sustained wind variation of 20 degrees or more from the posted bearing during the first leg of a race shall result in the race to be abandoned and re-sailed or abandoned. This changes the RRS 32.1.

9.6 A sustained wind variation of 40 degrees or more from the posted bearing during the first lap shall result in the race being abandoned and re-sailed or abandoned. For the purpose of this rule, a lap means the rounding of mark 3 (or passing the gate 3s-3p) for the first time. This changes the RRS 32.1.

9.7 The number of legs in a race may be reduced (RRS code flag S) but at least 2 (two) windward legs of the course shall be completed. This changes the RRS 32.2.

9.8 The wind speed ranges shall be no less than 5 knots and not exceed 23 knots or in accordance with the Rules of Conduct for Conducting National and International Championships and the applicable Deed of Gift. This changes rule 32.1.

## 10 MARKS

---

10.1 Marks 1, 2, 3, 3s and 3p will be cylindrical orange.

10.2 Mark 1 bis will be cylindrical yellow.

10.3 The port-end starting mark will be cylindrical yellow.

10.4 The finishing mark will be:

- mark 1 for "W", "O", and "T" courses;

- red cylindrical with a red flag for "W2", "O2", and "T2" courses.

10.5 Except at a gate, a Race Committee vessel signalling a change of a leg of the course is a mark as provided in SI 13.2.

10.6 If one of the marks "gate 3s-3p" is not placed, or is not replaced as per RRS 34, the remaining mark shall be left to port. This changes the RRS 34.

10.7 The new mark used for the change of the next leg of the course will be cylindrical yellow.

## 11 AREAS THAT ARE OBSTRUCTIONS

---

11.1 There are no areas, lines or objects designated as obstructions.

## 12 THE START

---

12.1 The races will start as per Rule 26 with the warning signal given 5 minutes before the starting signal.

12.2 The starting line will be between a staff displaying an orange flag on the Race Committee vessel at the starboard end and

the course side of the starting mark as provided in instruction 10.3

12.3 A boat starting later than 5 minutes after her starting signal will be scored Did Not Start without a hearing. This changes Appendices A4 and A5.

12.4 RRS 30.4 is changed so that it will be applied in fleets with more than 45 boats and after the 2<sup>nd</sup> General Recall for that race.

12.5 The Race Committee, after the finish of a race and before the warning signal of a subsequent one, will do its best to post on the Race Committee vessel a list of OCS, or ZPF, UFD or BFD boats. The failure of posting or an incomplete or wrong list will not be grounds for redress. This changes the RRS 62.1(a).

12.6 To alert boats that a race or sequence of races will begin soon, the orange starting line flag will be displayed with one sound at least 5 minutes before a warning signal is made.

## 13 CHANGE OF THE NEXT LEG OF THE COURSE

---

13.1 To change the next leg of the course, the Race Committee will lay a new mark (or move the finishing line) and remove the original mark as soon as practicable. When in a subsequent change a new mark is replaced, it will be replaced by an original mark.

13.2 Except at a gate, boats shall pass between the race committee boat signalling the change of the next leg and the nearby mark, leaving the mark to port and the Race Committee vessel starboard. This changes the RRS 28.

13.3 After the completion of first windward leg of the race the remaining legs may be increased or decreased by not more than 30% of the original length. This changes the RRS 33.

13.4 If Mark 1 will be changed in courses “W” or “W2”, Mark 1bis (offset) will no longer be a course mark.

## 14 THE FINISH

---

14.1 The finish line will be between a staff displaying a blue flag on a Race Committee vessel and the course side of the finishing mark.

14.2 The A flag displayed on the Race Committee boat at the finish means that there will be no more races for the day.

## 15 TIME LIMITS AND TARGET TIMES

---

15.1 The races will be managed to last 60-75 minutes for the first boat to finish. A different time (shorter or longer) used to complete the race will not be ground for requesting redress. This changes 62.1.

15.2 The time limit for the first boat to complete the first lap is 40 minutes from the start. If the first boat fails to complete the first lap within 40 minutes the Race Committee shall abandon the race. For the purpose of this rule a lap means the rounding of Mark 3 (or passing the Gate 3s/3p) for the first time.

15.3 The time limit for the first boat to finish the race shall be 1 hour and 30 minutes. Any boat finishing more than 30 minutes after the first boat finishes or failing to finish within 2 hours from the start, whichever is shorter shall be scored Did Not Finish (DNF). This changes RRS 35, A4 and A5.

## 16 HEARING REQUESTS

---

16.1 Protest forms are available at the race office, located at the race office. Protests and requests for redress or reopening shall be delivered there within the appropriate time limit.

16.2 The protest time limit is 90 minutes after the last boat has finished the last race of the day or the Race Committee signals no more racing today, whichever is later.

16.3 Notices will be posted no later than 30 minutes after the protest time limit to inform competitors of hearings in which they are parties or named as witnesses at the following url:  
<https://federvela.coninet.it/#/manifestazioni/60534/note> (for Italian championship)  
<https://federvela.coninet.it/#/manifestazioni/60496/note> (for German Open)

Hearings will be held in the protest room, located at the club house beginning at the time posted.

16.4 Notices of protests by the Race Committee, Technical Committee or Protest Committee will be posted at following url

<https://federvela.coninet.it/#/manifestazioni/60534/note> (for Italian championship)

<https://federvela.coninet.it/#/manifestazioni/60496/note> (for German Open)

to inform boats under RRS 61.1(b).

16.5 The penalty for breaking rules in the SI marked with [SP] may be applied at the discretion of the Race Committee, without a hearing, and shall be the 5% scoring penalty for nearest race



completed by the infringing boat but not worse than a DSQ. This changes the RRS 63.1 and the Appendix A5.

16.6 Penalties for breaking Class Rules may be less than disqualification. This changes 64.2.

16.7 Per Appendix N2.2, SCIRA reserves for itself the right and responsibility to decide issues of eligibility, measurement and equipment.

16.8 For the purpose of RRS 64.4(b) the “authority responsible” is the Measurer of the event.

16.9 The Jury will abandon the race if, during a redress hearing, they conclude that the Race Committee did not follow Sailing Instructions 9.5, 9.6, 9.7,9.8 and 13.3. This changes the RRS 64.3.

16.10 A list of boats that have been penalized for breaking RRS 42, RRS 29.1(OCS) or 30.1(OCS) or 30.2(ZPF) 30.3(UFD), 30.4 (BFD), will be posted on the Official Notice Board.

16.11 On the last scheduled racing day:

- a request of redress shall be delivered within the protest time limit or 30 minutes after incident occurred, whatever the latest deadline (changes RRS 62.2)

- a request for reopening a hearing shall be delivered:

- a) within the protest time limit if the requesting party was informed of the decision on the previous day (changes RRS66);

- b) no later than 30 minutes after the requesting party was informed of the decision on that day (changes RRS 66).

## 17 SCORING

---

17.1 One (1) races are required to be completed to constitute a series.

17.2 (a) When fewer than 5 races have been completed, a boat’s series score will be the total of her race scores.

(b) When from 5 to 8 races have been completed, a boat’s series score will be the total of her race scores excluding her worst score.

17.3 The title of Italian Champion will be awarded only if at least 3 races are sailed.

## 18 [NP][DP] SAFETY REGULATIONS

---

18.1 A boat that retires from a race shall notify the Race Committee as soon as possible.

## 19 REPLACEMENT OF CREW OR EQUIPMENT

---

19.1 The same crew shall race in all races, except for reasons satisfactory to the Race Committee. Requests for a change of crew shall be submitted in writing to the Chairman of race committee. Once a crew has been excused, he/she may not return for the balance of the series.

19.2 The same skipper shall sail all races and can be replaced after the first race only, and then only if he/she is obviously incapacitated. If a skipper is replaced the first race shall be the race excluded.

19.3 [DP] Substitution of hull, sails, appendages, and rig will not be allowed unless authorized in writing by the TC/RC. Requests for substitution shall be made to the committee at the first reasonable opportunity, which may be after the race.

## 20 OFFICIAL VESSELS

---

20.1 Official boats will be marked by displaying the flag of Associazione Velica Trentina.

## 21 [DP] RADIO COMMUNICATIONS

---

21.1 A boat that is racing shall not make voice or data transmissions and shall not receive voice or data communication that is not available to all boats, except in an emergency or when using equipment provided by the race committee.

## 22 [NP] [DP] TRASH DISPOSAL

---

22.1 Trash may be placed aboard support and Committee Vessels.

Marcello Montis - Race Committee Chairman

Stefano Longhi - SCIRA Representative